

REVISIONS			
REV	DESCRIPTION	DATE	APPROVED

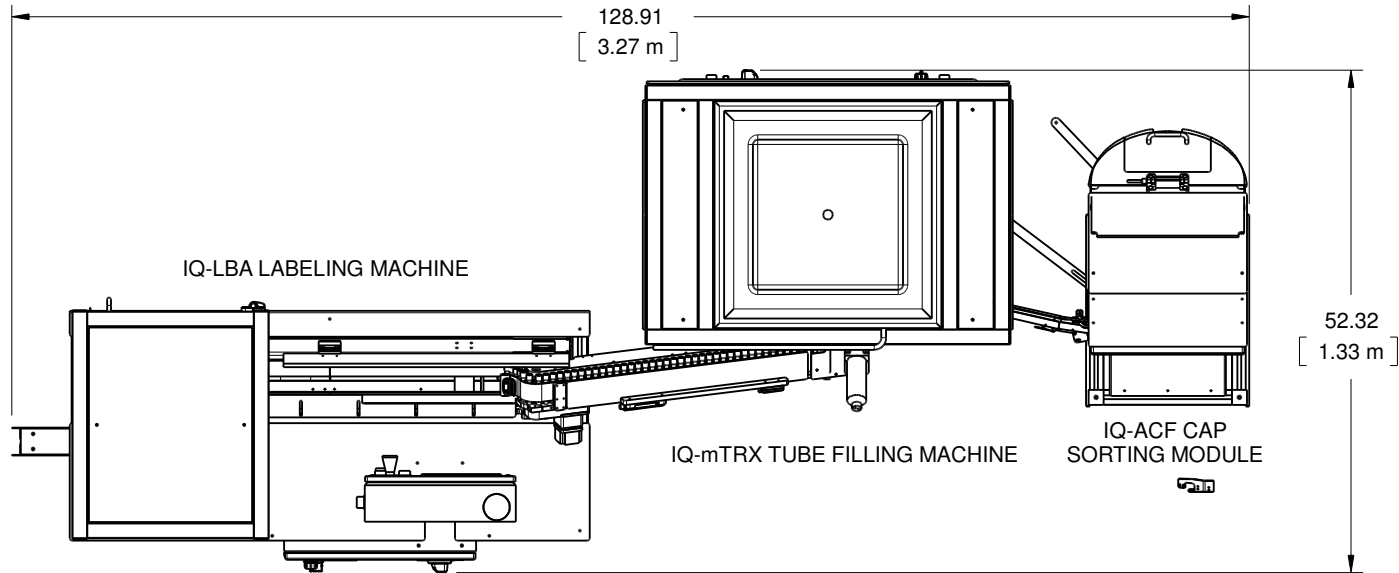

IQ-mTRX + ACF + LBA SPECIFICATIONS

- * mTRX SHOWN WITH ACF CAP FEEDER AND LBA LABELING MACHINE
- * MAXIMUM 2,700 TUBES PER HOUR
- * AUTOMATIC CAP DESCRAMBLING
- * AUTOMATIC TUBE LABELING
- * OUTPUT INTO BULK BIN

IQ-mTRX + ACF + LBA SERVICE REQUIREMENTS

ELECTRICAL: 120/240V AC INPUT, 10A
 PNEUMATIC: 80PSI @ 6CFM

MODEL TRX	<h1 style="margin: 0;">IQ Designs</h1> <p style="margin: 0;">Manistique, MI USA</p>			
DATE 11.06.2024				
DRAWN BY RWG	SIZE A	NAME MAIN ASSEMBLY, mTRX + ACF + FLO	DWG NO. TRX-000-0021	REV -
MATERIAL XXX	SCALE 1:20	TOLERANCE X.XXX +/-0.005"	SHEET 1 OF 1	