



## AUTOMATION FOR THE DIAGNOSTICS INDUSTRY

- FILLING SYSTEMS FOR PETRI DISHES, TUBES & BOTTLES
- MEDIA PREPARATION & STERILIZATION
- PACKAGING SYSTEMS
- COMPLETE DIAGNOSTICS PRODUCTION SYSTEMS

PO Box 311 / 462N Klagstad Road Manistique, MI 49854, USA Phone: (906) 341-1040 [www.iqdesignsusa.com](http://www.iqdesignsusa.com)

# IQ-FLO Flow Wrapping System

The IQ-FLO Flow Wrapping System by IQ Designs, Inc. is a great addition or upgrade to any producer who wants to automate packaging. Package product straight out of a filling machine with automated integration, or manually load product into the flow wrapper from stored production.

## System Highlights

- Create packages with common materials such as cellophane, nylon, or oriented polypropylene
- Touch screen interface

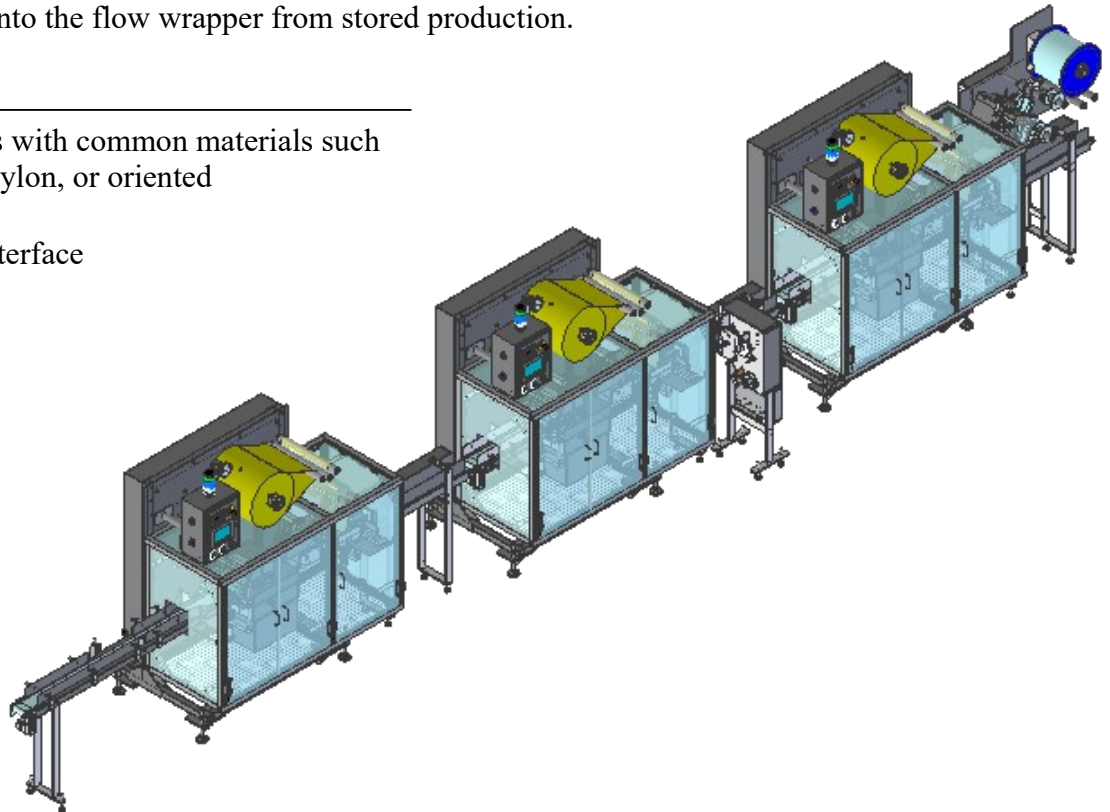

## Standard Features

- Configure as either one stack of ten or two stacks of five dishes
- Customized layout per production needs
- Siemens PLC & touchscreen controls
- Designed & manufactured in the USA
- Around the clock customer support
- IQ/OQ documentation included
- CE marked

## Upgrades Available

- Change parts for most petri dish types
- Double or triple bagging
- Desiccant pack insertion
- Irradiation label application
- Product label application
- Custom input and output conveyor systems
- HEPA enclosure
- Package custom products

**System shown: FLO**

**Speed: Up to 600 packages per hour**

**Footprint: 4.1m x 1.5m**

**Material: Nylon**

**Configuration:**

10-stack laydown

90mm petri dish

Contact petri dish

**Options:**

Label application

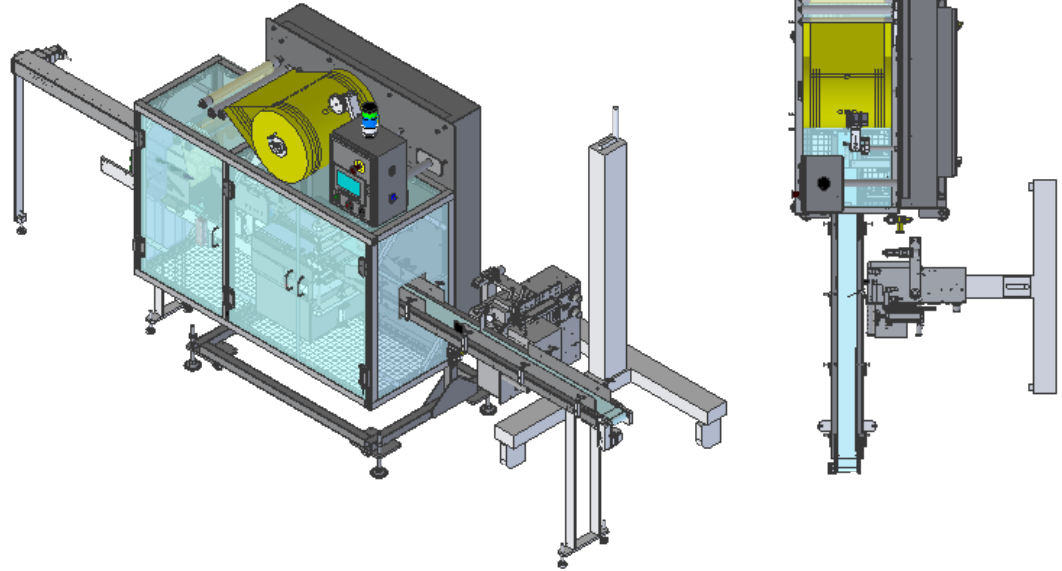

**System shown: FLO**

**Speed: Up to 750 packages per hour**

**Footprint: 3.0m x 1.2m**

**Material: OPP**

**Configuration:**

5x5 side by side

90mm petri dish

Contact petri dish

55mm petri dish

**Options:**

HEPA enclosure

